

# ADA GUIDE FOR SMALL BUSINESSES

## Course Author:

U.S. Small Business Administration & U.S. Department of Justice

## 2 Professional Development Hours

## Instructor:

Marc A. Broome, P.E., P.S.

## Provided by:

Cornerstone Education Services, LLC  
P.O. Box 384  
Sumrall, Mississippi 39482

[www.PDHUniversity.com](http://www.PDHUniversity.com)





U.S. Small Business Administration  
Office of Entrepreneurial Development

U.S. Department of Justice  
Civil Rights Division



## Americans with Disabilities Act

# ADA Guide for Small Businesses



The U.S. Small Business Administration is pleased to work with the U. S. Department of Justice in assisting small businesses to understand and comply with the Americans With Disabilities Act.

## **Reproduction**

Reproduction of this document is encouraged.

## **Disclaimer**

The ADA authorizes the Department of Justice to provide technical assistance to individuals and entities that have rights or responsibilities under the Act. This document provides informal guidance to assist you in understanding the ADA and the Department's regulation. However, this technical assistance does not constitute a legal interpretation of the statute.

SBA Authorization #99-2111-26

# Table of Contents

---

Introduction .....	1
The Americans with Disabilities Act .....	1
Businesses that Serve the Public: Public Accommodations .....	2
Existing Facilities .....	2
Architectural Barriers .....	3
Removing Architectural Barriers .....	3
Priorities for Barrier Removal .....	3
Examples of Barrier Removal .....	3
Accessible Parking .....	4
Accessible Entrance .....	6
Doors at Entrances to Businesses .....	8
Turnstiles and Security Gates at Entrances .....	8
Shelves and Maneuvering Space .....	10
Sales and Service Counters .....	11
Serving Counters .....	12
Fixed Seating and Tables .....	13
Policies and Procedures .....	14
Communicating with Customers .....	14
Tax Credits and Deductions .....	14
New Construction and Alterations .....	15
ADA Information Sources .....	15



## Introduction

This guide presents an informal overview of some basic ADA requirements for small businesses that provide goods or services to the public. It omits many of the “legal” terms that are found in the ADA and its regulations. But because it would be misleading to separate any explanation of ADA requirements from the law, references to key sections of the regulations or other information are included.



*To get answers to questions about the ADA or to learn more about the law call the Department of Justice ADA Information Line, toll-free (1-800-514-0301 voice and 1-800-514-0383 TDD).*

## The Americans with Disabilities Act

The Americans with Disabilities Act (ADA) is a Federal civil rights law that prohibits the exclusion of people with disabilities from everyday activities, such as buying an item at the store, watching a movie in a theater, enjoying a meal at a local restaurant, exercising at the local health club or having the car serviced at a local garage. To meet the goals of the ADA, the law established requirements for private businesses of all sizes. These requirements first went into effect on January 26, 1992, and continue for both for-profit and non-profit organizations.

For small businesses, compliance with the ADA is not difficult. To help businesses with their compliance efforts, Congress established a technical assistance program to answer questions about the ADA.

Answers to your questions about the ADA are a phone call away. The Department of Justice operates a toll-free ADA Information Line (800- 514-0301 voice and 800-514-0383 TDD). In addition, tax credits and deductions were established that can be used annually to offset many costs of providing access to people with disabilities.

In recognition that many small businesses can not afford to make significant physical changes to their stores or places of business to provide accessibility to wheelchair users and other people with disabilities, the ADA has requirements for existing facilities built before 1993 that are less strict than for ones built after early 1993 or modified after early 1992.

## Private Businesses that Serve the Public: Public Accommodations

Private businesses that provide goods or services to the public are called public accommodations in the ADA. The ADA establishes requirements for twelve categories of public accommodations, including stores and shops, restaurants and bars, service establishments, theaters, hotels, recreation facilities, private museums and schools and others. Nearly all types of private businesses that serve the public are included in the categories, regardless of size.

If you own, operate, lease, or lease to a business that serves the public, then, you are covered by the ADA and have obligations for existing facilities as well as for compliance when a facility is altered or a new facility is constructed. Existing facilities are not exempted by "grandfather provisions" that are often used by building code officials.

*This booklet focuses on businesses that provide goods and services to the public.*

*These businesses may be large or small and can be for profit or non-profit.*



### Existing Facilities

Many business facilities were built without features that accommodate people with disabilities, including people who use wheelchairs. This lack of accessibility makes it impossible for many people with disabilities to take part in everyday activities such as going to work, eating in a restaurant or shopping in a store. The ADA recognizes that, for people with disabilities to participate in the everyday activities in their communities, they need to have access to the goods and services provided by businesses.

While it is not possible for many businesses, especially small businesses, to make their facilities fully accessible, there is much that can be done without much difficulty or expense to improve accessibility. Therefore, the ADA requires that accessibility be improved without taking on excessive expenses that could harm the business.

If you own or operate a business that serves the public you must remove physical "barriers" that are "readily achievable," which means



*easily accomplishable without much difficulty or expense.* The "readily achievable" requirement is based on the size and resources of the business. So larger businesses with more resources are expected to take a more active role in removing barriers than small businesses. The ADA also recognizes that economic conditions vary. When a business has resources to remove barriers, it is expected to do so; but when profits are down, barrier removal may be reduced or delayed. Barrier removal is an ongoing obligation -- you are expected to remove barriers in the future as resources become available.

## Architectural Barriers

Architectural barriers are physical features that limit or prevent people with disabilities from obtaining the goods or services that are offered. They can include parking spaces that are too narrow to accommodate people who use wheelchairs; a step or steps at the entrance or to part of the selling space of a store; round doorknobs or door hardware that is difficult to grasp; aisles that are too narrow for a person using a wheelchair, electric scooter, or a walker; a high counter or narrow checkout aisles at a cash register, and fixed tables in eating areas that are too low to accommodate a person using a wheelchair or that have fixed seats that prevent a person using a wheelchair from pulling under the table.

### Removing Architectural Barriers

In evaluating what barriers need to be removed, a business should look to the ADA Standards for Accessible Design as a guide. These standards are part of the ADA Title III regulations. Seeking input from people with disabilities in your community can also be an important and valuable part of the barrier removal process because they can help identify barriers in your business and offer advice on what solutions may work.

When a business removes barriers, it should follow the design requirements for new construction in the ADA Standards for Accessible Design (Standards). In some cases, existing conditions, limited resources or both will make it not “readily achievable” to follow these Standards fully. If this occurs, barrier removal measures may deviate from the Standards so long as the measures do not pose a significant risk to the health or safety of individuals with disabilities or others.



*These parking spaces are too narrow and lack a wide access aisle so people who use wheelchairs cannot get out of their vehicle.*



*The awning and awning support over the walk to the entrance is too close to the ground and is a barrier to people who are blind or visually impaired.*

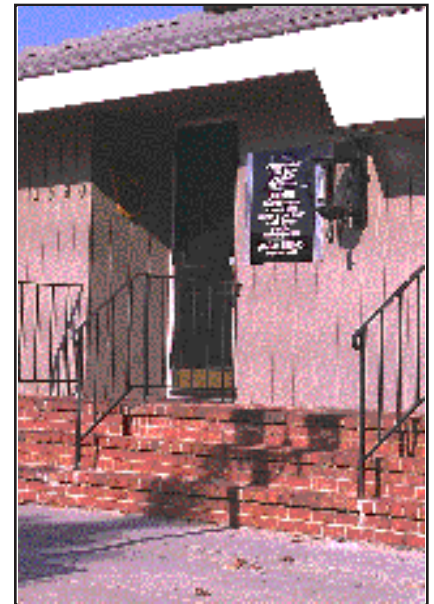

*Any step at the entrance can stop people from visiting your business.*

### Priorities for Barrier Removal

When deciding which barriers to remove first, we suggest that you first provide access to the business from public sidewalks, parking, and public transportation and then provide access to the areas where goods and services are made available to the public. Once these barriers are removed, you should provide access to public toilet rooms (if toilet rooms are provided for customer use). When these barriers have been removed, it may be necessary to remove any

remaining barriers including those that limit use of public telephones and drinking fountains.

### Examples of Barrier Removal

The following examples illustrate common barriers and suggest solutions that may be readily achievable. Each business must decide on a case-by-case basis what constitutes “readily achievable” barrier removal for their business.



## Accessible Parking

When parking is provided for the public, designated accessible parking spaces must be provided, if doing so is readily achievable. An accessible parking space must have space for the vehicle and an additional space located either to the right or to the left of the space that serves as an access aisle. This aisle is needed to permit a person using a wheelchair, electric scooter, or other mobility device to get out of their car or van. A sign with the international symbol of accessibility must be located in front of the parking space and mounted high enough so it is not hidden by a vehicle parked in the space.

Accessible parking spaces should be the spaces closest to the accessible entrance and be located on level ground. If it is not readily achievable to locate accessible parking in the closest spaces due to sloped pavement or other existing conditions, then the closest level area should be selected. An accessible route must be provided between the access aisle and the accessible building entrance. This route must have no steps or steeply sloped surfaces and it must have a firm, stable, slip-resistant surface.

Van accessible spaces must have an access aisle that is **at least eight-feet wide** and be designated by a sign with the international symbol and "van accessible." There should be a vertical clearance of at least 98 inches on the vehicular route to the space, at the parking space, and along the vehicular route to an exit.

Provide a parking space that is at least 8 feet wide. There should be at least a 98 inch high clearance at the parking space, the adjacent access aisle and along the vehicular route to the space and vehicular exit.

Install a sign with the international symbol of accessibility and "van accessible" and mount it high enough so it is not hidden by the vehicle parked in the space.



Locate parking space and access aisle so that they are relatively level (1:50 maximum slope in all directions is recommended if readily achievable)

Provide an access aisle that is at least 8 feet wide next to the van parking space to permit a person using a wheelchair or scooter to exit or enter a van with a side-mounted lift.

Provide an accessible route to the accessible entrance(s) to the building - a marked crosswalk may be needed if route crosses vehicular traffic.

### A Van Accessible Parking Space

(1 of 8 of all accessible parking spaces, but at least one, must be van accessible.

Although designated a van accessible space, cars may use the space too.)

Note: locate accessible parking spaces as close as possible to the accessible entrances and on an accessible route to the building.

Install a sign with the international symbol of accessibility and mount high enough so sign is not hidden by a vehicle parked in the space.

Locate parking space and access aisle on relatively level ground (1:50 maximum slope in all directions)



Two parking spaces may share a common access aisle (van or car).

Install curb ramp where an accessible route crosses a curb - note: curb ramp does not extend into the access aisle.

Note: Accessible parking spaces for cars must have an access aisle that is at least five feet wide.

Accessible parking spaces for cars must have an access aisle that is **at least five-feet wide**. The other features are the same as for vans, except that the sign designating the parking space only has an international symbol of accessibility, and there is no requirement for a minimum vertical height.

The number of accessible parking spaces that should be provided is based on the total number of parking spaces that you provide. For example, if your parking lot has 25 or fewer spaces, then 1 should be an accessible parking space. If it has 50 or fewer spaces, it should have 2 accessible parking spaces.

If you provide only one accessible parking space, it also must be a van accessible space. In facilities where more than one accessible parking space is required, one of eight accessible parking spaces must be van accessible.

Where parking is provided in several locations near building entrances, the accessible parking should also be dispersed, if doing so is readily achievable. Since van accessible parking spaces are provided in limited numbers, it is often not possible to disperse the van accessible parking spaces.

## An Accessible Parking Space for Cars

## Accessible Entrance

Providing physical access to a facility from public sidewalks, public transportation, or parking is basic to making goods and services available to people with disabilities. Having only one step at the entrance can prevent access by a person using a wheelchair, walker, or cane and can make entry difficult for many other people with mobility disabilities.

Where one or two steps exist at an entrance, access can be achieved in a variety of ways -- for example, by using an alternate accessible entrance, adding a short ramp, modifying the area in front or to the side of the entrance to eliminate a step, or installing a lift.

When a business has two public entrances, in most cases, only one must be accessible. The shop shown in the photo (bottom right) has a street entrance and is also served by an accessible entrance from the building lobby at the other side of the store. Using the lobby entrance provides access to the store. When one entrance is not accessible and another entrance is accessible, a sign must provide direction to the accessible entrance. The alternative entrance must be open during store hours. If the alternative accessible entrance is not left unlocked due to security concerns, you must provide an accessible way for notifying staff to open the door, such as a buzzer or bell. If used, the buzzer or call bell must be located on an accessible route and mounted at an accessible height (generally not more than 48 inches above ground).



Edge protection prevents people from rolling over the edge of the ramp.

Wide landing accommodates turns needed to enter or exit the store.

**A new ramp with edge protection, handrails and a wide landing outside the entrance provide access to this business**

When a ramp is added to provide an accessible entrance, the slope of the ramp should be as shallow as possible but not more than 1:12. It is also important to provide handrails whenever the slope is

more than 1:20 and the vertical rise is greater than 6 inches (a slope of 1:20 means that for every 20 units of horizontal length there is one unit of vertical rise or fall). It is best to grade the area that is

Example of a sign that directs customers to the nearest accessible entrance



**Signage provided at an inaccessible entrance provides direction to another entrance that is accessible**

adjacent to the ramp to avoid an abrupt drop-off. If a drop-off exists, then a barrier such as a raised edge or railing must be installed. Edge protection is very important because it prevents people from accidentally rolling off the edge of the ramp. The ramp that is shown (page 6, top right) uses railings and edge protection. Edge protection could also be provided by a lower railing installed parallel to the ramp surface.

The photo (upper right) illustrates another way to modify an entrance to make it accessible. A level landing area is provided in front of the entry door so a person can pull the door open. The area adjacent to the landing is graded flush with the landing so no drop-off exists between the landing and the grass area eliminating the need for railings. The earth is also graded flush with the ramp surface to eliminate a drop-off.

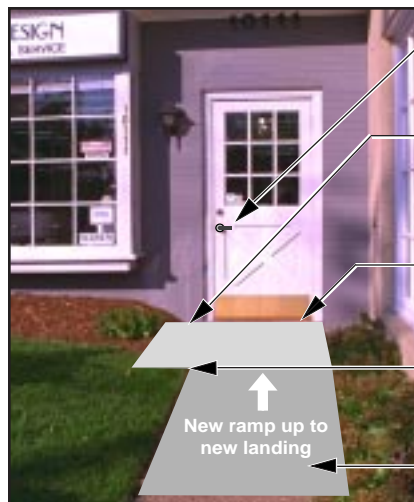

- Lever handle added to or in place of round door knob.
- Landing extends 18" minimum beyond the edge of door and 60" minimum out from door.
- New landing and ramp eliminates step at entrance.
- Earth is graded up to landing and ramp to eliminate drop off.
- Ramp slope max. 1:12 and width is 36" minimum

**A new landing, ramp and lever door handle provide an accessible entrance to this business**

Another approach to providing access at an entrance is to use a platform or folding lift. Lifts are mechanical devices that can be used to transport a person using a wheelchair or scooter up or down several feet. A lift may be a preferred solution where little space exists for a ramp or when an entrance serves more than one

level. For example, had the bookstore shown in the photo (page 6, bottom right) not had an alternate entrance that was accessible, a lift could have been installed. Lifts require periodic maintenance and must meet safety codes but are worthwhile considerations when a ramp is not feasible.



**Home delivery, take-out, curbside delivery or other alternate service is required, if readily achievable, when you cannot make an entrance accessible**

When it is not readily achievable to provide an accessible entrance, the goods and services must be provided in some other way, if doing so is readily achievable. For example, if a restaurant has several steps at the entrance and no accessible entry is possible, providing home delivery or some alternative service may be required. In other cases, it may be possible to receive an order by telephone and to have a clerk bring the order to the customer outside the store or business. If alternative service is provided, it is important that it be publicized so a customer knows how the goods and services are offered.

## Doors at Entrances to Businesses

Most entrances to stores and businesses use 36 inch wide doors that are wide enough to be accessible. However, some older doors are less than 36 inches wide and may not provide enough width (32 inch clear width when fully opened). Door openings can sometimes be enlarged. It may also be possible to use special “swing clear” hinges that provide approximately 1 1/2 inches more clearance without replacing the door and door frame.

Inaccessible door hardware can also prevent access to the business. For example, the handle shown below requires the user to tightly grasp the handle to open the door. Many people with mobility disabilities and others with a disability that limits grasping, such as arthritis, find this type of handle difficult or impossible to use.

**NOT ACCESSIBLE**

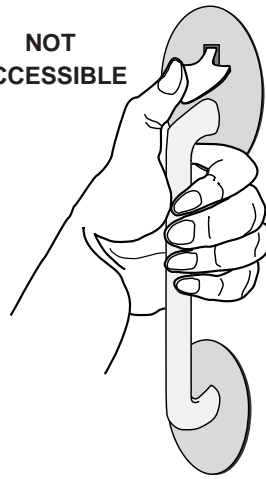

**This handle with a thumb latch is not accessible because one must grasp the handle and pinch down on the thumb latch at the same time.**

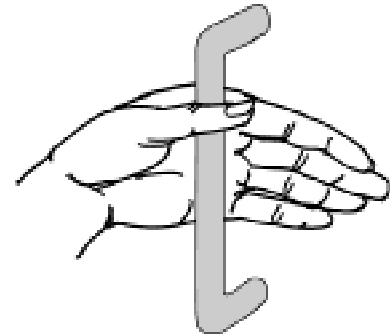

**A loop-type handle is also accessible because it can be used without grasping, pinching or twisting.**

## Turnstiles and Security Gates at Entrances

Businesses with narrow revolving turnstiles located at the entrance exclude people with disabilities unless accessible gates or passages are provided. Standard narrow turnstiles are not usable by wheelchair users and by most people who walk with crutches, walkers, or canes. Whenever a narrow turnstile is used, an accessible turnstile, gate or opening must be provided, if doing so is readily achievable.

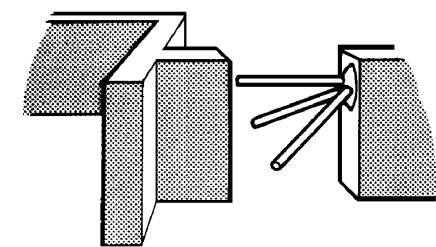

**This type of turnstile is not accessible to most people with disabilities.**

**NOT ACCESSIBLE**

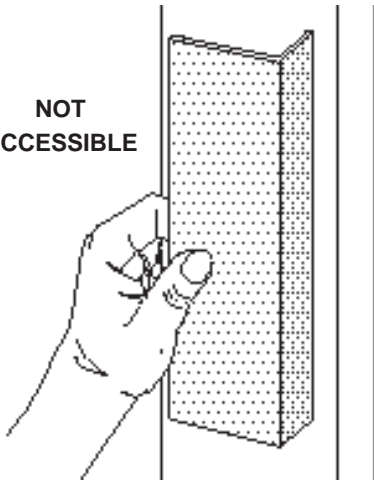

**This panel-type handle is not accessible because it requires the user to tightly grasp the handle to pull the door open.**

Other types of door hardware, such as a round door knob (which requires tight grasping and twisting to operate) or a handle with a thumb latch (see above -- center) are also inaccessible and must be modified or replaced, if doing so is readily achievable.

Changing or adding door hardware is usually relatively easy and inexpensive. A round doorknob can be replaced with a lever handle or modified by adding a clamp-on lever. In some cases, a thumb latch can be disabled so the door can be pulled open without depressing the latch or the hardware may be replaced. A flat panel-type pull handle can be replaced with a loop-type handle.

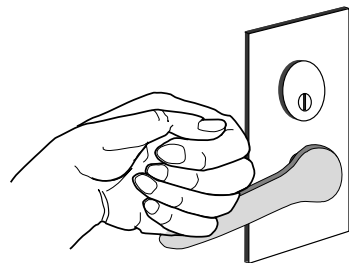

**A lever handle is accessible because it can be operated without tight grasping, pinching or twisting.**

If an inaccessible turnstile is located at the entrance to the business and no accessible gate or entry is provided, it must be replaced or removed or an alternative accessible entrance provided, if doing so is readily achievable. For most businesses, removing or altering the turnstile is not difficult. For some businesses, providing an alternative accessible entrance may be an acceptable solution if the business has two or more doors that could function as entrances. For example, a store that has an inaccessible turnstile at the entrance but also has an exit door (with no turnstile) located near the cash register may be able to use the exit door as an alternative entrance. It may be readily achievable to add an accessible door handle to the outside of the exit door, install a sign that designates this door as the accessible entrance, and permit people with disabilities to enter through the exit door.

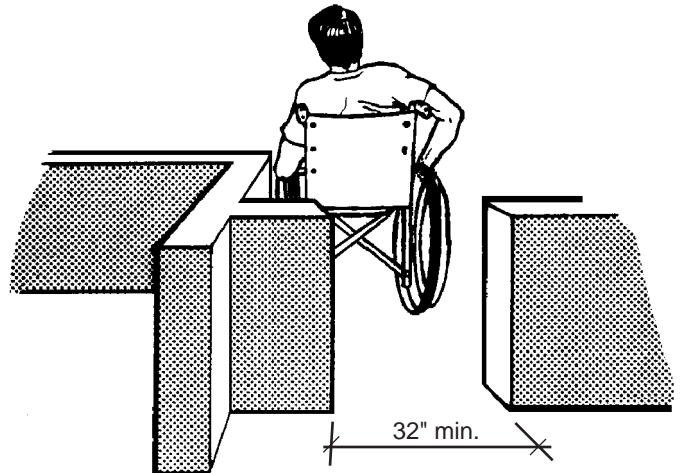

Removing the turnstile to provide an accessible passageway

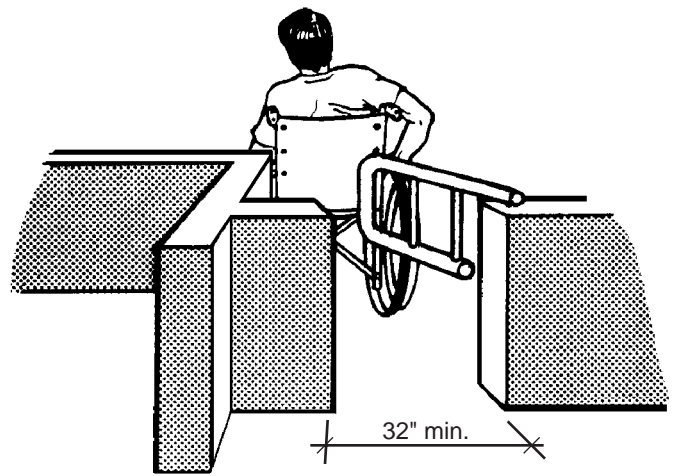

An example of an accessible gate

Eliminating the barrier caused by a turnstile may be accomplished by simply removing the turnstile and leaving the opening. To assure passage of people using wheelchairs, or crutches, the opening must be at least 32 inches wide. If it is not readily achievable to provide a minimum 32 inch wide opening, then the opening should be as wide as possible. If a security gate is required, then the turnstile may be removed and replaced with an accessible gate, if readily achievable. Where a business wishes to retain its standard turnstile, it may provide an accessible gate adjacent to the turnstile.

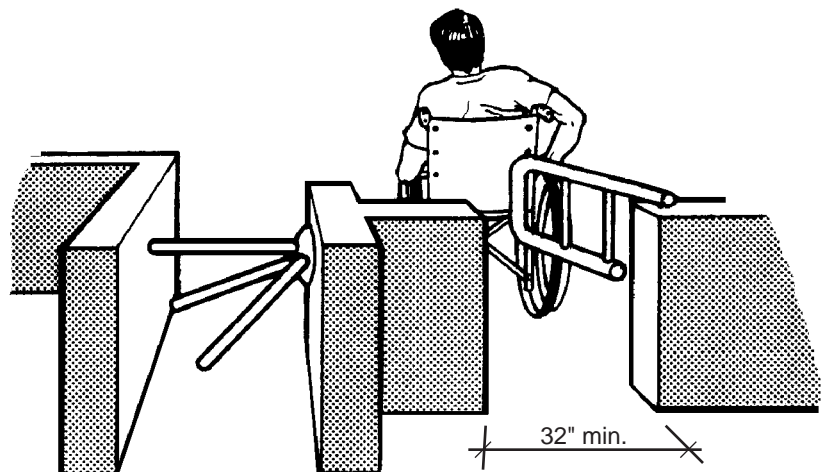

An accessible gate provided adjacent to a turnstile

## Shelves and Maneuvering Space

After ensuring that its entrance is accessible, a business must consider how people with disabilities will get to the items that are sold or provided. When sales items are displayed or stored on shelves for selection by customers, the store must provide an accessible route to fixed shelves and displays, if doing so is readily achievable.

If the maneuvering space adjacent to shelves and displays is too narrow, the space should be widened. In general, a 36 inch wide accessible route is needed with a slightly larger space provided at corners. If a 180 degree turn is needed to exit an area, then a 60 inch diameter turning space or a 36 inch wide "T" is needed. The space for a "T" turn requires at least 36 inches of width for each segment of the T and it must fit within a 60 inch by 60 inch area.

Some businesses will have difficulty providing enough maneuvering space between all displays and shelving without a significant reduction in selling space that may substantially affect the profitability of the business. This fact can be considered in determining if it is readily achievable to provide access to all sales areas. If access is not provided to all sales areas, then alternative services such as having staff available to retrieve items, must be provided, if doing so is readily achievable. This also applies when merchandise is located in areas served only by stairs.

It is not necessary to locate all merchandise within reach of people who use wheelchairs. Items can be placed at any height but staff should be available to assist customers who may have difficulty reaching or viewing items.

Sales items may be located at any height but sales staff should be available, on request, to reach items for customers

Provide at least a 3' by 3' turning space at a corner for a 90 degree turn.

Sales merchandise, displays and other items can block access and should not be placed in narrow aisles. These books block the 3'-0" accessible route



3'-0" minimum width to move between shelves, displays and merchandise

**Provide a 36" minimum width route between displays and shelves if readily achievable**



Staff assist customers by retrieving merchandise from shelves and displays.

Staff should provide information about an item by reading labels for people with a visual impairment.

**Sales staff retrieving items for customer**

## Sales and Service Counters

When sales or service counters are provided, the counters must be accessible, if doing so is readily achievable. This access is an important part of receiving the goods and services provided by a business.

At counters having a cash register, a section of counter at least 36 inches long and not more than 36 inches above the floor will make the counter accessible. This provides a lowered surface where goods and services and money can be exchanged. An alternative solution is to provide an auxiliary counter nearby.

At sales and service counters, such as ticketing counters, teller stations in a bank, registration counters in hotels and motels, and other counters where goods or services are sold or distributed a counter that is at least 36 inches long and that is not more than 36 inches above the floor will make the counter accessible. It is also possible to provide an auxiliary counter nearby or to use a folding shelf or area next to the counter, if doing so is readily achievable.

In addition to having a maximum height of 36 inches, all accessible sales and service counters must have a clear floor space in front of the accessible surface that permits a customer using a wheelchair to pull alongside. This space is at least 30 inches by 48 inches and may be parallel or perpendicular to the counter. It is also connected to the accessible route which connects to the accessible entrance and other areas in the business where merchandise or services are provided.

If you cannot provide an accessible sales or service counter or auxiliary counter nearby, such as a table or desk, you may provide a clip board or lap board for use until a more permanent solution can be implemented.

Accessible counter is at least 36" long and no more than 36" above the floor

Provide a 30" by 48" space in front of the sales or service counter to accommodate a wheelchair or electric scooter



**An accessible sales counter at a cash register**

Checkout aisles, such as in a grocery store, have different requirements. An accessible checkout aisle should provide a minimum of a 36-inch-wide access aisle and it should be identified by a sign with the international symbol of accessibility mounted over the aisle. The counter adjacent to the accessible checkout aisle has a maximum height of 38 inches. If a lip is provided between the counter and the checkout aisle, its maximum height is 40 inches.

The number of accessible aisles that is needed depends on the total number of checkout aisles provided. For example, if one to four aisles are provided, then at least one should be accessible. If more

than five to eight aisles are provided, then two accessible aisles are needed. Each type of checkout, including express lanes, must have an accessible checkout aisle.

The ADA Standards for Accessible Design provide detailed information on the requirements for checkout aisles and for sales and service counters.



## Serving Counters

Where food or drinks are served at counters and the counter height is more than 34 inches above the floor, providing a lowered section of the serving counter at least 60 inches long and no higher than 34 inches will make the counter accessible. If it is not readily achievable to make the counter accessible, a business can serve the items at nearby accessible tables, if readily achievable.

When it is not readily achievable to provide an accessible counter or bar area or service at accessible tables in the same area, then a business should provide service in an alternative manner, if doing so is readily achievable. This may include offering to assist the customer by moving items to an accessible counter or to their table in another area.

Self-service restaurants with a food service line must provide adequate maneuvering space for a person using a wheelchair to approach and move through the line, if doing so is readily achievable. A minimum width of 36 inches should be provided with a 42 inch width preferred, if readily achievable. If the line changes direction, such as a 180 degree turn, an extra wide turning space is needed. An alternative solution, in an existing facility, is to provide an accessible route around the queuing area.

If self-service condiments, utensils, or tableware are provided, then they should be located no higher than 54 inches if a side reach is possible or 48 inches for a forward reach (see Section 4.2 of the ADA Standards for Accessible Design). If it is not readily achievable to provide these items in an accessible location, a business can provide staff assistance, if doing so is readily achievable.



**Lowered serving counter provides an accessible space to select and receive food items**

Door under counter can be opened to provide required knee clearance when customers eat at the counter



Lowered shelf was added to provide an accessible surface for preparing coffee

**Lowered shelf provided for condiment items**

## Fixed Seating and Tables

If tables are provided, such as in restaurants and snack bars, and the tables are attached to the wall or floor (fixed), then 5% of the tables or at least one (if less than 20 are provided) must be accessible, if doing so is readily achievable. Accessible seating must be provided, if doing so is readily achievable, at each accessible table to accommodate people using wheelchairs. Movable chairs can be used for these tables and the movable chairs can be removed when customers using wheelchairs use the table(s).

The same requirements apply to fixed tables in outdoor areas such as picnic areas, playgrounds or patios.

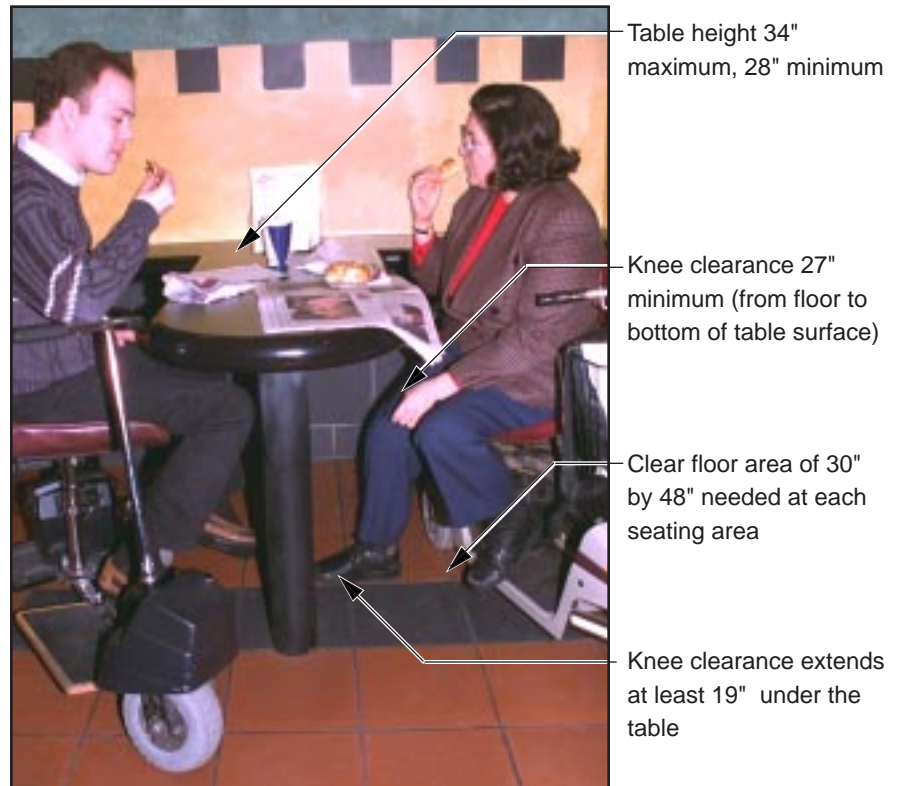

**Accessible seating positions  
at a permanently-mounted table**

*When fixed seating  
or fixed tables  
are provided,  
accessible seating must be  
provided,  
if readily achievable*

An accessible table has a surface height of no more than 34 inches and no less than 28 inches above the floor. At least 27 inches of knee clearance must be provided between the floor and the underside of the table. An accessible route provides access to each accessible table and a clear floor area 30 inches by 48 inches is provided at each accessible seating location. This clear floor area extends 19 inches under the table to provide leg and knee clearance.

If it is not readily achievable to provide the minimal number of accessible tables in all areas where fixed tables are provided, then the services must be provided in another accessible location, if doing so is readily achievable. However, these alternate location(s) must be available for all customers and not just people with disabilities. It is illegal to segregate people with disabilities in one area by designating it as an accessible area to be used only by people with disabilities.

## Policies and Procedures

Businesses must review their policies and procedures for serving customers and change those that exclude or limit participation by people with disabilities. For example, if a store has a policy to exclude all animals, the policy should be changed to permit people who use service animals, such as "seeing-eye-dogs" and "hearing-assist-dogs" to enter the store with their service animals. A store that has a special accessible entrance that remains locked during business hours will need to change the policy and keep the door unlocked when the store is open. If security is a problem, an accessible call box or buzzer (identified by a sign and mounted in an accessible location and height) should be installed to enable people with disabilities to call staff to unlock the door. A restaurant that restricts seating of people with disabilities to one area must revise the policy to permit the range of choices enjoyed by others.

## Communicating with Customers

Customers who have hearing or speech disabilities may need to communicate with sales staff without using speech. The method of communication will vary depending on the abilities of the customers and on the complexity of the communications that are required. For example, some people who are deaf are able to use speech but unable to understand words spoken by others while other people who are deaf are not able to communicate with speech. People with speech or hearing disabilities may require extra time to complete their message or extra attention by staff to understand what is being said. When communication by speech is not possible, simple questions,

such as the price of an item, may be handled with pen and paper by exchanging written notes or a mixture of speech and written notes. Staff should be aware of the need to use notes or both speech and communication with pen and paper. It is appropriate to ask the customer what is their preference for simple communication.

When more complex or lengthy communications are needed, it may be necessary to provide a sign language interpreter in, for example, negotiating the purchase of an automobile or home. But most business communications with customers involve only simple communications that can be done using pen and paper.

Many people with hearing or speech disabilities use a telecommunications device for the deaf (TDD) instead of a standard telephone. This device has a keyboard for entering messages and a visual display to view the content of a conversation from another person using a TDD.

To make it easy for people who use a TDD to communicate with businesses and individuals who do not have a TDD, the ADA established a free state-by-state relay network nationwide that handles voice-to-TDD and TDD-to-voice calls. Customers who use a TDD to make telephone calls may telephone your business using a relay network. The relay consists of an operator with a TDD who translates TDD and voice messages. For example, a caller using a TDD calls the relay operator who then calls your business. The caller types the message into the TDD and the operator reads the message to you. You respond by talking to the operator who then enters your message into the TDD.

Operators are trained to provide an exact interpretation and to not become personally involved in the conversation and are required to maintain confidentiality.

Calls using a relay take a little longer. You may also use the relay network to place a voice call to a customer who uses a TDD.

## Tax Credits and Deductions

To assist businesses with complying with the ADA, Section 44 of the IRS Code allows a tax credit for small businesses and Section 190 of the IRS Code allows a tax deduction for all businesses.

The tax credit is available to businesses that have total revenues of \$1,000,000 or less in the previous tax year or 30 or fewer full-time employees. This credit can cover 50% of the eligible access expenditures in a year up to \$10,250 (maximum credit of \$5000). The tax credit can be used to offset the cost of undertaking barrier removal and alterations to improve accessibility; providing accessible formats such as Braille, large print and audio tape; making available a sign language interpreter or a reader for customers or employees, and for purchasing certain adaptive equipment.

The tax deduction is available to all businesses with a maximum deduction of \$15,000 per year. The tax deduction can be claimed for expenses incurred in barrier removal and alterations.

To learn more about the tax credit and tax deduction provisions, contact the DOJ ADA Information Line (see Information Sources for the numbers).

## **New Construction and Alterations**

The ADA requires that newly constructed facilities, first occupied on or after January 26, 1993, meet or exceed the minimum requirements of the ADA Standards for Accessible Design (Standards). Alterations to facilities, spaces or elements (including renovations) made on or after January 26, 1992, also must comply with the Standards. If you build a new facility or modify your existing one, (for example, work such as restriping the parking area, replacing the entry door or renovating the sales counter), make sure to consult the Standards and the title III regulations for the specific requirements. Renovations or modifications are considered to be alterations when they affect the usability of the element or space. For example, installing a new display counter, moving walls in a sales area, replacing fixtures, carpet or flooring, and replacing an entry door. However, simple maintenance, such as repainting a wall is not considered an alteration by the ADA.

Many communities also have State or local accessibility codes enforced by local building inspectors. When a local accessibility code exists, you must follow both the code and the ADA requirements.

## **ADA Information Sources**

### **Department of Justice ADA Information Line**

The ADA Information Line provides information and technical assistance on the ADA Standards for Accessible Design and other ADA provisions applying to businesses, non-profit service agencies and state and local government programs. Information Specialists are available to answer general and technical questions during business hours on weekdays. The Information Line also provides 24 hour automated service for ordering ADA materials and an automated fax back system that delivers technical assistance materials to fax machines or fax modems.

800-514-0301 (voice)  
800-514-0383 (TTY)

Internet  
[www.ada.gov](http://www.ada.gov)

### **Disability and Business Technical Assistance Centers (DBTACs)**

The ten regional centers are funded by the Department of Education to provide technical assistance on the ADA. One toll-free number connects to the center in your region.

800-949-4232 (voice & TTY)

### **Access Board**

Offers technical assistance on the ADA Accessibility Guidelines.

800-872-2253 (voice)  
800-993-2822 (TTY)

Internet  
[www.access-board.gov](http://www.access-board.gov)

### **Equal Employment Opportunity Commission (EEOC)**

The EEOC offers technical assistance on the ADA provisions for employment which apply to businesses with 15 or more employees.

Employment questions  
800-669-4000 (voice)  
800-669-6820 (TTY)

Employment documents  
800-669-3362 (voice)  
800-800-3302 (TTY)

### **Small Business Information Source**

#### **Small Business Administration**

800-827-5722 (voice/relay)  
(800-U ASK SBA)

Internet  
[www.sba.gov](http://www.sba.gov)